



## Owner's Manual

R-CU-INM—Issue 8

PACIFIC SOLAR PTY LIMITED  
ACN 067 478 666  
82-86 BAY STREET BOTANY  
NSW 2019 SYDNEY AUSTRALIA  
TELEPHONE (+61 2) 9316 6811  
FACSIMILE (+61 2) 9666 4079  
WEB [www.pacificsolar.com.au](http://www.pacificsolar.com.au)  
EMAIL [info@psolar.com.au](mailto:info@psolar.com.au)





# Welcome

Congratulations on your purchase of a **/Plug & Power/** rooftop photovoltaic system. Using **/Plug & Power/**, you can enjoy the benefits of generating your own environmentally friendly electricity, straight from the sun!

This manual describes the components of your **/Plug & Power/** system, including operating instructions for your **Sunlogger**. Please take a few moments to read it.

## Important warnings

-  Your **/Plug & Power/** system contains no user serviceable parts. Do not attempt to open or modify any part of your system, as this may present a risk of electric shock. Should any repair or modification be required, please contact your local distributor.
-  Installation and removal of your **/Plug & Power/** system must only be carried out by a qualified person.
-  The solar modules in your **/Plug & Power/** system can be damaged by severe force. Dangerous levels of DC and AC voltage may be present in a damaged system.



# Contents

<b>Part 1 - Understanding /Plug &amp; Power/</b>	<b>1</b>
How /Plug & Power/ works	2
Maintaining your /Plug & Power/ system	3
Metering	4
Loss of supply	5
System additions	6
<b>Part 2 - Sunlogger</b>	<b>7</b>
Introducing the Sunlogger	8
Sunlogger controls	9
Status screen	10
Using the menu system	12
The Main Menu	13
Present data	14
Today's data	17
Historical data	18
Configuration	20
Troubleshooting	22
<b>Part 3 - Sundown</b>	<b>25</b>
Introducing Sundown	26
Connection and installation	27
Getting started with Sundown	29
Communication settings	30
Sundown Control Panel	32
Generating plots	33
Exporting data from Sundown	37
<b>Appendix - Energy efficiency</b>	<b>39</b>



---

PART 1

# Understanding **/Plug & Power/™**

## How **/Plug & Power/™** works

Your **/Plug & Power/** system converts sunlight falling on your roof directly into electricity using a process known as the ‘photovoltaic effect’. The system consists of one or more photovoltaic (PV) **modules**. Each module consists of a solar panel, roof mount and DC-to-AC inverter (shared between two solar panels) for converting the DC electricity produced by the panel into grid-compatible AC electricity.

In most cases, your **/Plug & Power/** system will have been connected directly to the same switchboard that delivers your household electricity. You are therefore able to use the electricity generated by your **/Plug & Power/** system directly. Any excess is fed back into the electricity distribution network, for which your electricity supplier will provide you with a credit.

# Maintaining your /Plug & Power/™ system

Your /Plug & Power/ system requires virtually no maintenance. Since there are no moving parts to wear out, your system should continue to operate reliably for many years.

The amount of electricity produced by your /Plug & Power/ system depends on how much sunlight it receives. If possible, shading of the system from trees and other obstructions should be avoided. Heavy soiling of module surfaces from leaves or bird droppings can also adversely affect performance.

If your system is mounted on a sloping roof, it will be periodically self-cleaned by the action of rainwater. If your system is mounted on a flat or almost flat roof, performance may be improved slightly by occasionally cleaning the front surface of each module with tap water. Do not use solvents, detergents or harsh cleaning agents.

# Metering

Your **/Plug & Power/** system is connected directly to the electricity distribution network (grid) used by your local electricity supplier. The arrangements used for metering of your **/Plug & Power/** system are determined by your local electricity supplier. Please contact your supplier if you have any questions regarding metering.

If you are using more electricity than your **/Plug & Power/** system can produce, any shortfall will be supplied by the grid. Your electricity supplier will charge you for this just as it always has.

There are several types of metering arrangement. In some cases, your electricity supply and **/Plug & Power/** system may operate through the same meter. The meter will monitor your electricity use in the normal fashion, except that it may turn more slowly whenever your **/Plug & Power/** system is operating. If the output of your **/Plug & Power/** system exceeds your electricity use, the meter will operate in the reverse direction, thereby reducing your electricity bill.

In other cases, a second meter may be used to measure the excess electricity produced by your **/Plug & Power/** system. The first meter will monitor your electricity use in the normal fashion, except that it may turn more slowly whenever your **/Plug & Power/** system is operating. If your **/Plug & Power/** system produces excess electricity, this meter will stop and the second meter will measure the amount of excess fed back into the grid. The electricity supplier will provide a credit for this excess.

Under a third metering scheme, a second meter may be used to measure electricity fed into the grid by your **/Plug & Power/** system, for which the electricity supplier will provide a credit. Your original meter will simply measure your electricity use in the normal manner.

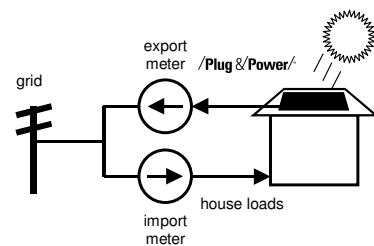
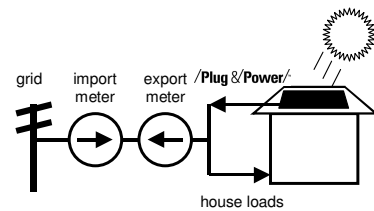
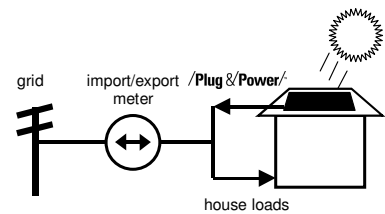

# Loss of supply

If there is a disruption to your local electricity supply, such as a blackout or brownout, your **/Plug & Power/** system will automatically switch off. Your **/Plug & Power/** system cannot provide electricity to your house during blackouts - this is a safety feature. When electricity supply is restored, your **/Plug & Power/** system will automatically switch on again.

# System additions

Your **/Plug & Power/** system can be expanded to suit your needs. Up to 20 solar panels can be connected to your system, with no additional wiring required. With additional wiring, your system can be expanded to accommodate as many solar panels as you require.

---

PART 2

# Sunlogger

# Introducing the Sunlogger

Using your **Sunlogger**, you can monitor the performance of your **/Plug & Power/** system to see just how much green electricity you are producing from your rooftop. Your **Sunlogger** can display a wide range of information, including:

- the present power output of your entire system or individual inverters.
- a graphical display of historical outputs for up to 18 months.

Your **Sunlogger** also features:

- automatic fault detection
- two serial output ports for communication with a modem or personal computer (PC). (See Part 3, starting on page 25, for further information on using your **Sunlogger** with a PC.)

# Sunlogger controls

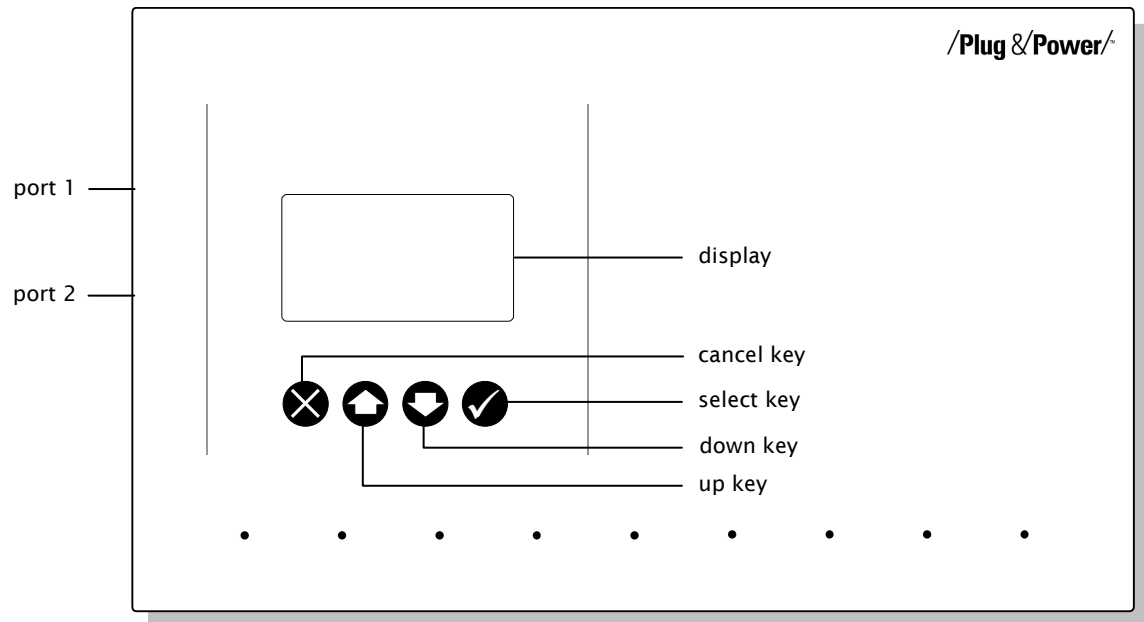

# Status screen

During normal operation, your **Sunlogger** will display a STATUS SCREEN. This screen shows:

- the present status of your system
- the present output of your system
- any warning messages.

## System status

The status of your **/Plug & Power/** system is indicated by one of several faces. The system status is updated every few minutes.



### Smiling face

A smiling face indicates that all inverters in your **/Plug & Power/** system are operating normally. This is the usual status of your system during the day.

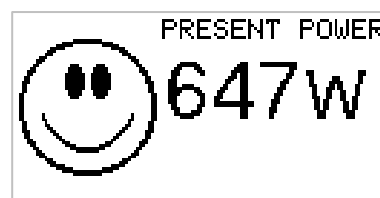

### Sleeping face

A sleeping face indicates that your **/Plug & Power/** system is producing little or no power. This is the usual status of your system at night or during periods of heavy cloud cover.



### Frowning face

A frowning face indicates a problem with your **/Plug & Power/** system. If your **Sunlogger** persistently displays this face, consult the **Troubleshooting** guide (p. 22).

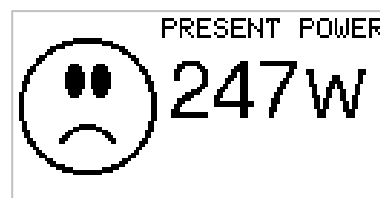

A sleeping and frowning face may also be displayed, indicating both a problem and a low power output from your **/Plug & Power/** system.

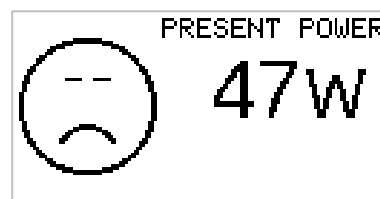

## System output

In addition to a face indicating the present status of your **/Plug & Power/** system, the STATUS SCREEN of your **Sunlogger** will also display the present output of your system, as follows:

### Present power

The STATUS SCREEN of your **Sunlogger** will show the total amount of electrical power your **/Plug & Power/** system is currently producing in watts. This value is updated every few seconds.



### Emissions of CO<sub>2</sub> saved

In alternation with the present power, your **Sunlogger** will also show the total amount of carbon dioxide (CO<sub>2</sub>) emissions, in kilograms, your **/Plug & Power/** system has saved from being emitted into the earth's atmosphere today.



### Today's energy

Instead of displaying saved CO<sub>2</sub> emissions, you can set your **Sunlogger** to show the total output of your system today in watt-hours. See page 15 for details on setting this option.

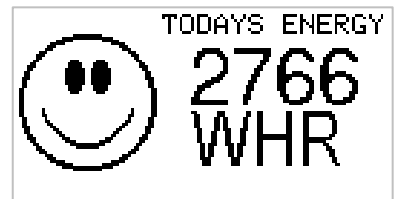

## Warning messages

The STATUS SCREEN of your **Sunlogger** may occasionally display a warning message.

### SET TIME warning message

Following installation of your **/Plug & Power/** system or a disruption to your local electricity supply, a SET TIME message may be displayed on the STATUS SCREEN of your **Sunlogger**. To clear this message, set the date and time using the procedures described on page 21.



# Using the menu system

Your **Sunlogger** features a menu system for accessing further information about your **/Plug & Power/** system, changing configuration settings and troubleshooting any problems.

The menu system consists of a number of **pages**. On many of these pages, you will see a list of options, any one of which can be selected to move to another page. Shown here is an outline of the menu system for your **Sunlogger**.

You can move through the menu system using the four keys on the front panel of your **Sunlogger**.

- ▶ To move up or down between menu items, press **⬆** (UP) or **⬇** (DOWN).
- ▶ To select a highlighted menu item and move to another page, press **✓** (SELECT).
- ▶ To cancel a selection and return to the previous page, press **✗** (CANCEL).

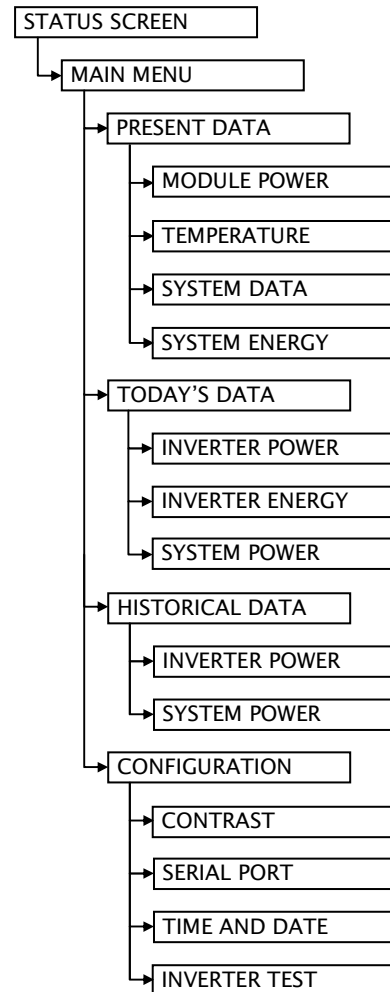

# The Main Menu



The MAIN MENU page of your **Sunlogger** is used to access all of the pages in the menu system.

▶ To access the MAIN MENU, press , ,  or .

When you access the MAIN MENU, four options are presented:

- PRESENT DATA. Displays information about the present performance of your **/Plug & Power/** system.
- TODAYS DATA. Displays graphs showing total system output and individual inverter output for today.
- HISTORICAL DATA. Displays graphs showing individual output and system output and for up to 550 previous days.
- CONFIGURATION. Displays the present **Sunlogger** configuration settings and allows these settings to be altered.

▶ To access any of these options

- 1 Press  or  until the desired option is highlighted.
- 2 Press .

▶ To return to the MAIN MENU, press .

```
MAIN MENU
PRESENT DATA
TODAYS DATA
HISTORICAL DATA
CONFIGURATION
```

# Present data



The PRESENT DATA page is accessed from the MAIN MENU. This page can be used to access information about the present performance of your /Plug & Power/ system.

When you access this page, four options are presented:

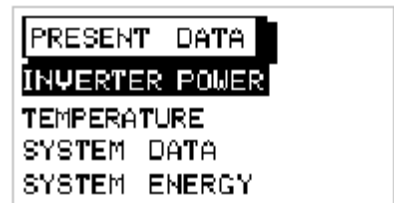
- INVERTER POWER
- TEMPERATURE
- SYSTEM DATA
- SYSTEM ENERGY.



## ▶ To access any of these options

- 1 Press  or  until the desired option is highlighted.
- 2 Press .

## ▶ To return to the PRESENT DATA page, press .

## Inverter Power

Select the INV. POWER option to display a graph showing the power output of each inverter in your /Plug & Power/ system.

Occasionally, an "N" may be displayed for one of the inverters. This indicates that the Sunlogger has not received any information from that inverter.

This can be due to a number of reasons including:

- Very low output from that inverter
- Unusual shading conditions especially early in the morning or late in the day
- Brief communications failure

In most of these cases, this is normal and the Sunlogger will begin receiving information from this inverter within a couple of minutes.

This option is not available whenever a sleeping face is displayed on the STATUS SCREEN.

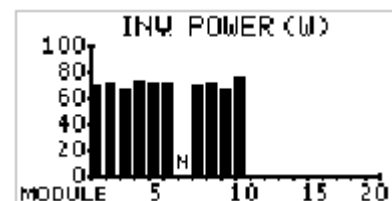
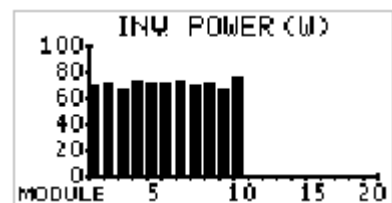

## System data

Select the SYSTEM DATA option to display the following information:

- SOLAR. Present power output of your **/Plug & Power/** system in watts.
- VOLTAGE. Present grid voltage in volts.
- CURRENT. Present grid current in amperes.
- FREQUENCY. Present grid frequency in hertz.

```
PRESENT SYSTEM DATA
SOLAR: 794.2W
VOLTAGE: 258.5V
CURRENT: 3.072A
FREQUENCY: 49.99HZ
```

## System energy

Select the SYSTEM ENERGY option to display the accumulated energy output of your **/Plug & Power/** system in kilowatt-hours or tonnes of carbon dioxide (CO<sub>2</sub>) emissions saved.

There are two values of system energy shown:



- 1 A user (U) value, which can be reset (similar to the trip meter on a car odometer). This is the total amount of electricity generated or consumed since the value was last reset
- 2 A total (T) value, which cannot be reset. This is the total amount of electricity generated or consumed since your **/Plug & Power/** system was installed.

```
ENERGY RESET KWHR
U SOLAR: 00116.053
T SOLAR: 00925.794
```

## Resetting system energy

You can reset the user-value system energy meter.

### ▶ To reset the system energy meter

- 1 Press  or  until RESET is highlighted.
- 2 Press .

```
ENERGY RESET KWHR
U SOLAR: 00000.000
T SOLAR: 00925.794
```

## Change between kWh and tons of CO<sub>2</sub>

You can toggle between displaying the energy output of your system on the SYSTEM ENERGY page and on the STATUS SCREEN in kilowatt-hours or in tons of carbon dioxide (CO<sub>2</sub>) saved.

### ▶ To toggle the display between kilowatt-hours and tons of CO<sub>2</sub>

- 1 Press  or  until KWHR or TONS CO2 is highlighted.
- 2 Press .



```
ENERGY RESET TONS CO2
U SOLAR: 00116.053
T SOLAR: 00925.794
```



# Today's data

The TODAY'S DATA page is accessed from the MAIN MENU. This page can be used to display graphs showing the performance of your /Plug & Power/ system over the course of today. When you access this page, three options are presented:

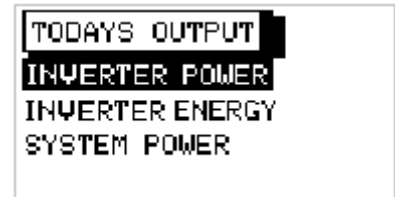
- INVERTER POWER
- INVERTER ENERGY
- SYSTEM POWER.



## ▶ To access any of these options

- 1 Press  or  until the desired option is highlighted.
- 2 Press .

## ▶ To return to the TODAY'S DATA page, press .

## Inverter Power

Select the INVERTER POWER option to display a graph showing the output of one of the inverters in your /Plug & Power/ system over the course of today.

## ▶ To display similar graphs for the other inverters in your /Plug & Power/ system, press or .

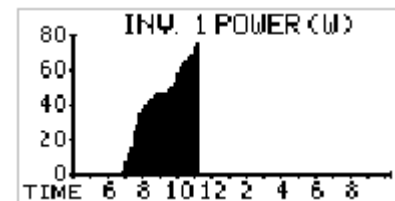

## Inverter Energy

Select the INV. ENERGY option to display a graph showing the cumulative energy output of each inverter in your /Plug & Power/ system (in watt-hours) over the course of today.

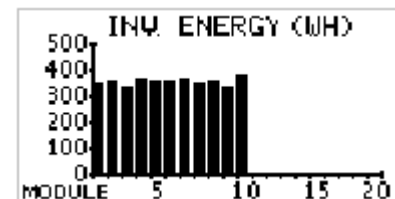

## System Power

Select the SYSTEM POWER option to display a graph showing the total output of your /Plug & Power/ system over the course of today.

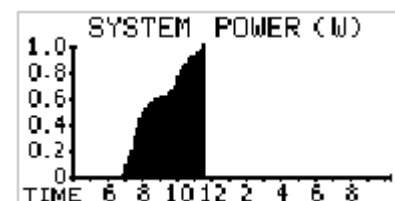



# Historical data

The HISTORICAL DATA page is accessed from the MAIN MENU. This page can be used to display graphs showing the performance of your /Plug & Power/ system for up to 550 previous days. When you access this page, two options are presented:

- INVERTER POWER
- SYSTEM POWER.

## ▶ To access either of these options

- 1 Press  or  until the desired option is highlighted.
- 2 Press .



## ▶ To return to the HISTORICAL DATA page, press .

## Inverter Power

Select the INVERTER POWER option to display a graph showing the historical output of one of the inverters in your /Plug & Power/ system.

You can display similar graphs for the other inverters in your /Plug & Power/ system.



## ▶ To display graphs for the other inverters

- 1 If necessary, press  so that the inverter number is flashing.
- 2 Press  to increase the displayed inverter number.
- 3 Press  to decrease the displayed inverter number.

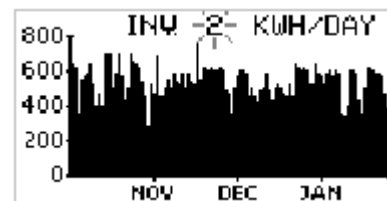
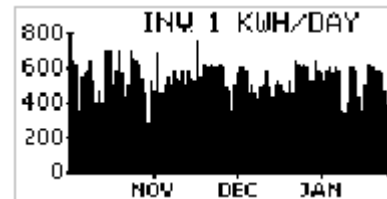
You can also adjust the time scale on the graph to increase or decrease the number of days shown between 110 and 550 (in increments of 110 days).



▶ **To adjust the time scale**

- 1 If necessary, press  so that the leftmost month label is flashing.
- 2 Press  to increase the number of days shown.
- 3 Press  to decrease the number of days shown.

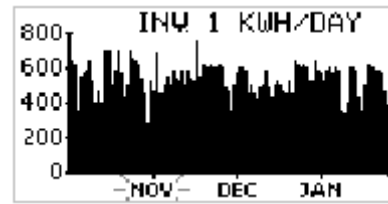



## System Power

Select the SYSTEM POWER option to display a graph showing the historical total output of your */Plug & Power/* system.

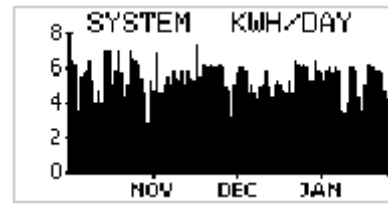
As with the INVERTER POWER option, you can adjust the time scale on the graph to increase or decrease the number of days shown.



▶ **To adjust the time scale**

- 1 Press  to increase the number of days shown.
- 2 Press  to decrease the number of days shown.

# Configuration

The CONFIGURATION page is accessed from the MAIN MENU. This page can be used to change the settings of your **Sunlogger** and carry out a diagnostic test. When you access this page, four options are presented:

- CONTRAST
- SERIAL PORT
- TIME AND DATE
- INVERTER TEST.

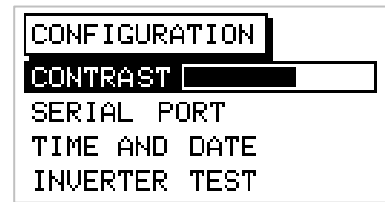

## ▶ To access any of these options

- 1 Press or until the desired option is highlighted.
- 2 Press .

## ▶ To return to the CONFIGURATION page, press .

## Contrast

Select the CONTRAST option to change the contrast of the display on your **Sunlogger**.

## ▶ To change the display contrast

- 1 Access the CONFIGURATION page and press or until the CONTRAST option is highlighted.
- 2 Press .
- 3 Press to increase the contrast.
- 4 Press to decrease the contrast.
- 5 Press to confirm the new contrast setting or to revert to the previous setting.

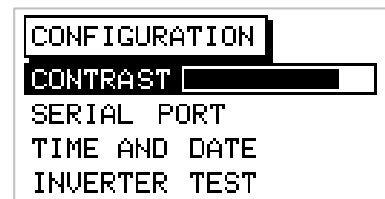

## Serial Port

Select the SERIAL PORT option to view or adjust the serial port settings of your **Sunlogger**. For further information on serial communication with your **Sunlogger**, see the section on using the Sundown program, starting on page 25.

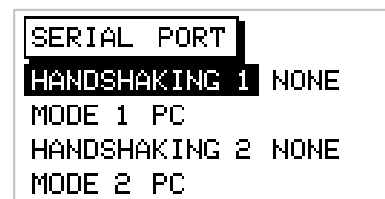





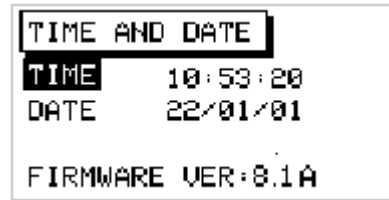





## Time and Date

Select the TIME AND DATE option to view or adjust the time and date settings of your **Sunlogger**. (The firmware version number will also be displayed.) Your **Sunlogger** displays the time using a 24 hour clock, and the date in DAY/MONTH/YEAR format.







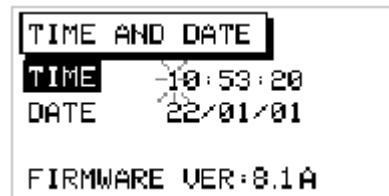





### ▶ To adjust the time

- 1 Access the CONFIGURATION page, press  or  until the TIME AND DATE option is highlighted and press  to select this option.
- 2 If necessary, press  or  until the TIME option is highlighted.
- 3 Press  to select this option. The first digit of the hour figure should begin flashing.
- 4 Press  to increase the digit.
- 5 Press  to decrease the digit.
- 6 Once the correct digit is displayed, press . The next digit should begin flashing.
- 7 Repeat steps 4–6 for the remaining digits, or press  to finish setting the time.



### ▶ To adjust the date

- 1 Access the CONFIGURATION page, press  or  until the TIME AND DATE option is highlighted and press  to select this option.
- 2 If necessary, press  or  until the DATE option is highlighted.
- 3 Press  to select the DATE option. The first digit of the day figure should begin flashing.
- 4 Press  to increase the digit.
- 5 Press  to decrease the digit.
- 6 Once the correct digit is displayed, press . The next digit should begin flashing.
- 7 Repeat steps 4–6 for the remaining digits, or press  to finish setting the date.



# Troubleshooting

Your **/Plug & Power/** system is a quality product that should continue to operate reliably for many years. Occasionally, however, the **Sunlogger** component of your system may display a frowning face. This does not necessarily indicate a fault with your system, but could be caused by shading of your modules or other transient factors.

## Frowning face

Your **Sunlogger** will display a frowning face whenever any of the inverters in your **/Plug & Power/** system produces little or no power for at least one day.

A frowning face will usually indicate a problem with your **/Plug & Power/** system, such as a faulty inverter. To determine the faulty inverter, run the INVERTER TEST (p.24). If this does not detect a fault, the problem may be due to some unusual shading conditions. In this case, the "smiling face" will return within a day or two.





If the INVERTER TEST is unable to detect a particular inverter, or the smiling face does not return within a day or two, then your **/Plug & Power/** system may require servicing.



## Inverter Test

The INVERTER TEST will determine if there is a problem with one or more of the inverters in your **/Plug & Power/** system.

### ▶ To run the INVERTER TEST



- 1 Access the CONFIGURATION page.
- 2 Press  until the INVERTER TEST option is highlighted.
- 3 Press  to access the INVERTER TEST page.
- 4 If necessary, press  so that the START option is highlighted.
- 5 Press .

Your **Sunlogger** will begin to test each inverter in sequence, up to a maximum of 10 inverters. The test may take a few minutes.

If your **Sunlogger** finds no problems with a particular inverter, the status of the inverter will be indicated as 'Y'. If the inverter is detected, but there is some communication problem, the status of the inverter will be indicated as '?'. If your **Sunlogger** is unable to detect an inverter, its status will be indicated as 'N'.

At any time, you can abort the test.

### ▶ To abort the test

- 1 During the test, press  so that the STOP option is highlighted.
- 2 Press . The test will stop.

INV TEST		START	STOP
ID	S	ID	S
1	Y	6	Y
2	Y	7	Y
3	Y	8	Y
4	Y	9	Y
5	Y	10	Y

INV TEST		START	STOP
ID	S	ID	S
1	Y	6	Y
2	Y	7	Y
3	Y	8	Y
4	Y	9	Y
5	Y	10	Y



PART 3

# Sundown

# Introducing Sundown

**Sundown** is an optional computer program that can be used with your **/Plug & Power/** system. Using **Sundown** in conjunction with a personal computer, you can monitor, log, analyse and graph the performance of your **/Plug & Power/** system.

**Sundown** can be used to display graphs and output data for your entire **/Plug & Power/** system over timescales ranging from minutes to months. You can also view the output of individual inverters and even your household electricity consumption. (This option is not available for all systems.)

The **Sundown** package is supplied with the following items:

- an installation CD-ROM
- a serial communication cable.

This section of the **/Plug & Power/** owner's manual will assist you in installing and using **Sundown**.

# Connection and installation

To use **Sundown**, you require a personal computer with the following minimum specifications:

- Pentium 125 MHz
- Windows 98/2000/Me/XP/NT (with service pack 6a)
- 32MB RAM
- 5 MB hard disk space
- CD-ROM drive
- one spare serial port.
- Microsoft .NET framework (This is installed automatically on setup if it is not already present. The .NET framework requires Internet Explorer version 5.01 or later, plus 35MB of hard disk space).

Before using **Sundown**, you need to connect your computer to the **Sunlogger** of your **/Plug & Power/** system using the serial cable supplied, and install **Sundown** on your computer.

## Connection

### ► To connect your computer and Sunlogger

- 1 Insert one end of the serial cable into port 1 of your **Sunlogger**.
- 2 Insert the other end of the serial cable into a spare serial communication port on your computer.



### Notes

**Sundown** can be used with one or two **Sunloggers**. To use an additional **Sunlogger**, simply connect it to a spare serial port on your computer.

If a serial extension cable is used, ensure the total length of the serial cable does not exceed 3 metres.

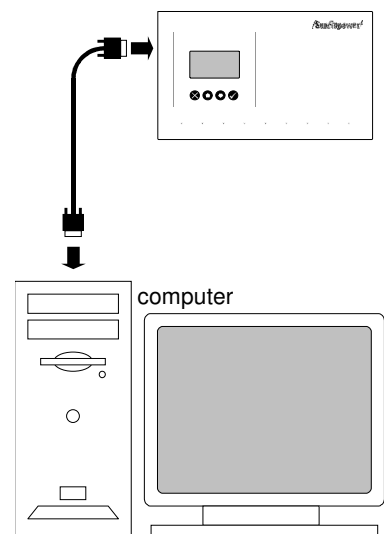

## Installation

### ▶ To install Sundown on your computer

- 1 Insert the installation CD-ROM.
- 2 From the **Start** menu, select **Run**, type “d:\setup” and click **OK**. (Alternatively, you can run **setup** from Windows Explorer.)
- 3 Follow the on-screen instructions

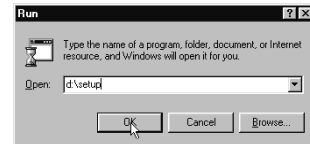

# Getting started with Sundown

Once you have completed the connection and installation procedures, you are ready to start using **Sundown**.

## ► To run Sundown

- 1 From the **Start Programs** menu, locate and click on the **Sundown** icon. After a few moments, the **Sundown Control Panel** should appear.
- 2 **Sundown** will attempt to establish communication with two **Sunloggers**. If you are using **Sundown** with a single **Sunlogger**, an error message will appear after a few seconds. Simply click **OK** to continue using **Sundown**.



If **Sundown** fails to establish communication with your **Sunlogger**, you may need to modify the communication settings. See the following section on **Communication Settings** for further information.

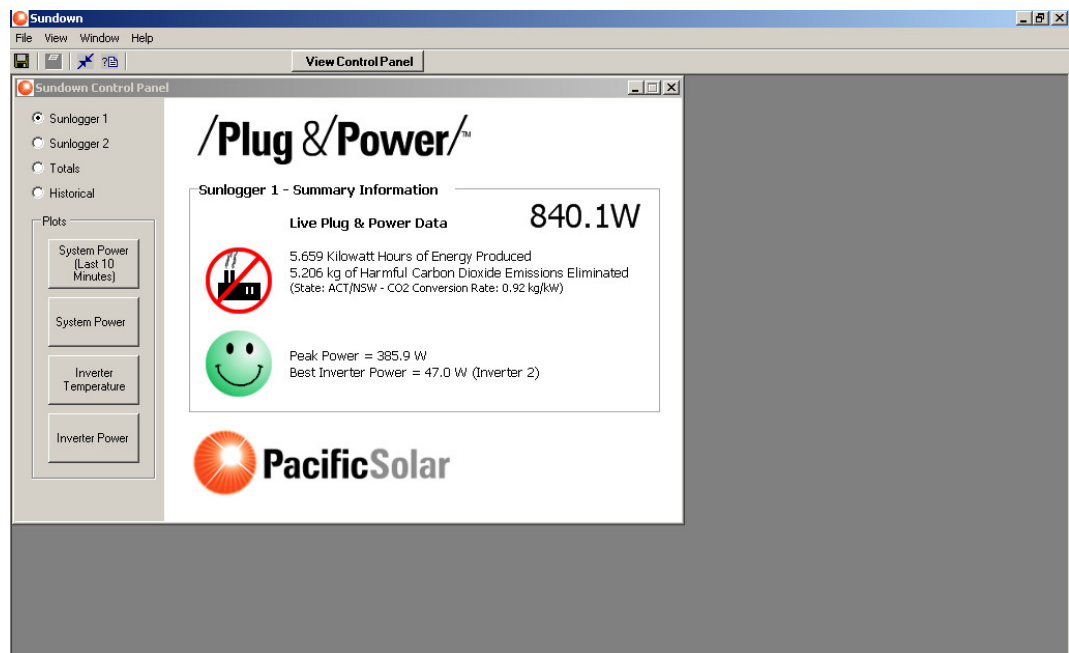

Sundown display at startup

# Communication settings

If **Sundown** is unable to establish communication with your **Sunlogger**, you may need to change the communication settings via the **Settings** window.

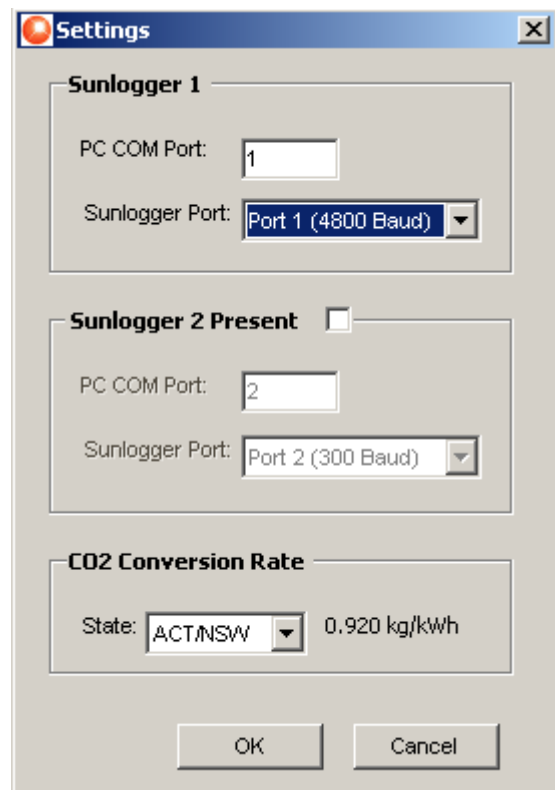

Settings window

## ► To change the communication settings

- 1 Under the **File** menu at the top of the screen, scroll down and click **Settings**. The **Settings** window should then appear.
- 2 Under the label **Sunlogger 1**, click on the **COM Port** field and type the number of the communication port on your computer to which your **Sunlogger** is connected.
- 3 Click on the **Sunlogger Port** pull-down menu and select the correct communication settings (see the following notes).

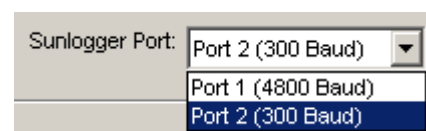
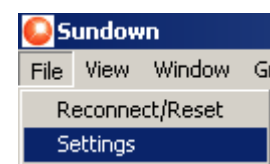

- 4 If you are using a second **Sunlogger**, check the box next to **Sunlogger 2 present**, and repeat steps 2–3 under the label **Sunlogger 2**.
- 5 When you have finished, click **OK** to close the **Settings** window.
- 6 Under the **File** menu at the top of the screen, scroll down and click **Reconnect/Reset** to establish communication with your **Sunlogger**.

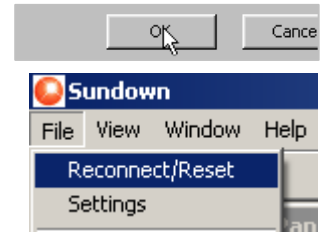

### Notes

If **Sundown** is still unable to establish communication with your **Sunlogger**, check the cable connection.

# Sundown Control Panel

You can generate plots and view information about your **/Plug & Power/** system using the **Sundown Control Panel**. The centre of the Control Panel displays information about the current performance of your **/Plug & Power/** system, namely

- the system status as represented by a smiling, sleeping, or frowning face (see page 10 for further information)
- the amount of carbon dioxide emissions eliminated by your system since it was installed
- the number of kilowatt-hours produced by your system since it was installed
- the current, live power output of your system
- the peak power output of your system
- the best power output from one of the inverters in your system.

The left side of the Control Panel features a number of buttons, which can be used to generate plots showing the performance of your **/Plug & Power/** system over time.

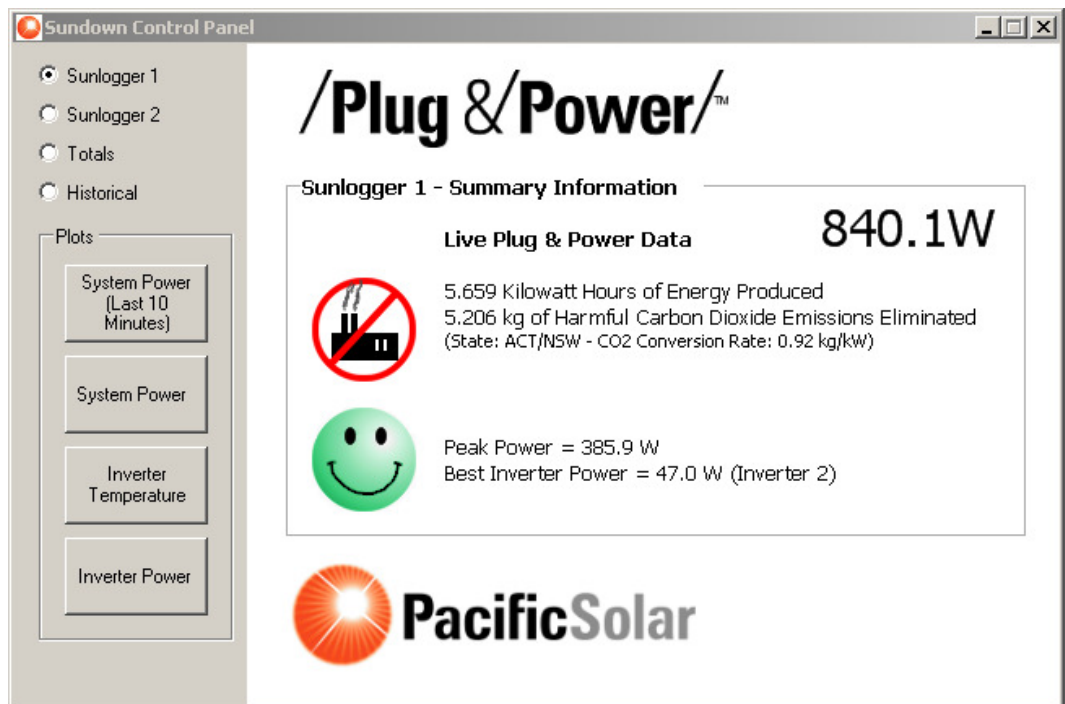

Sundown Control Panel

# Generating plots

**Sundown** is capable of generating various plots showing the performance of your **/Plug & Power/** system over periods ranging from 10 minutes to several months or years. You can also view your daily household electricity consumption (option not available for all systems). To generate a plot, simply click on the appropriate button. While **Sundown** is running, the plot will be continuously updated.

## Plotting system power

To generate a plot of your **/Plug & Power/** system's power output over the last 10 minutes, click on the button labelled **System Power – Last 10 Minutes**.

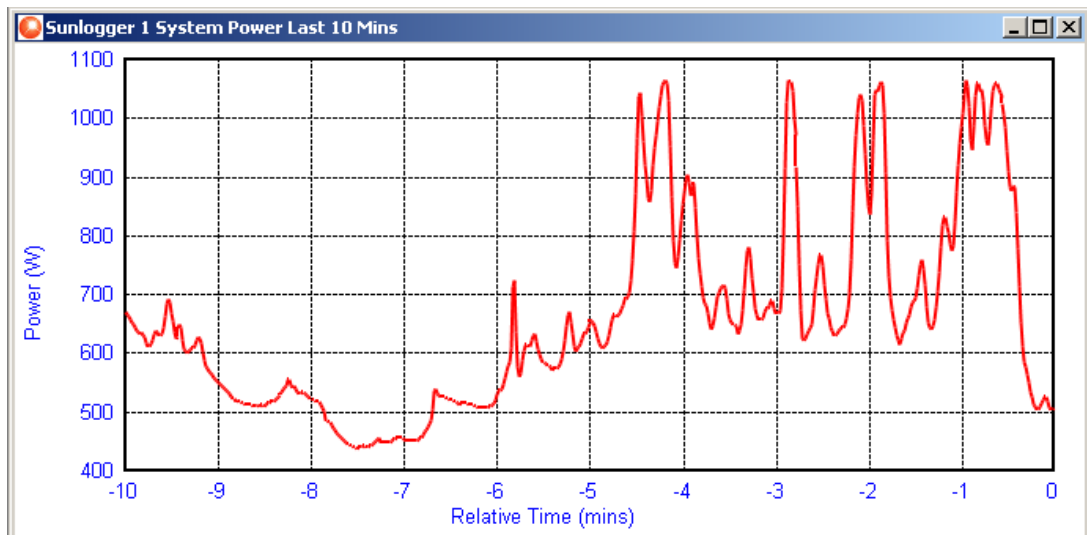
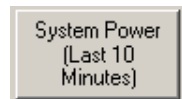

plot of system power output over last 10 minutes

To generate a plot showing your **/Plug & Power/** system's power output over the course of today, click on the button labelled **System Power**. This will also generate a plot showing your household power consumption, for easy comparison (option not available for all systems).

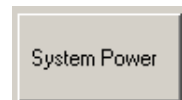

The system power plot is frozen at dusk, so that the full day's output may be viewed. The plot is refreshed following first light the next morning.

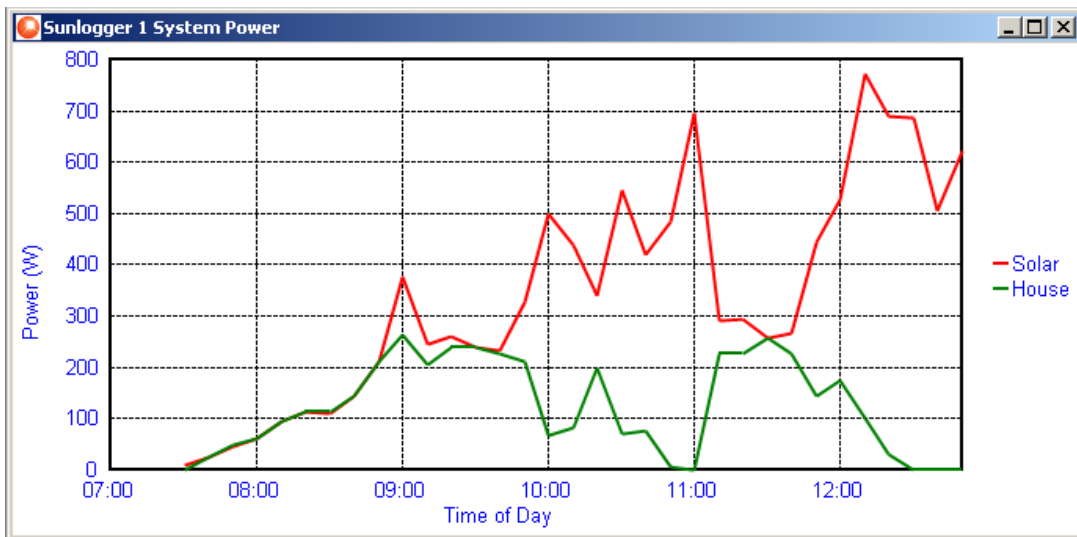

plot of system and household power for today

### Plotting inverter temperature

To generate a series of plots showing the temperature of each inverter in your **/Plug & Power/** system over the course of the day, click on the button labelled **Inverter Temperature**.

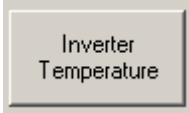

As for the system power plots, the inverter power plots are frozen at dusk and refreshed at dawn.

### Plotting inverter power

To generate a series of plots showing the power output of each inverter in your **/Plug & Power/** system, click on the button labelled **Inverter Power**

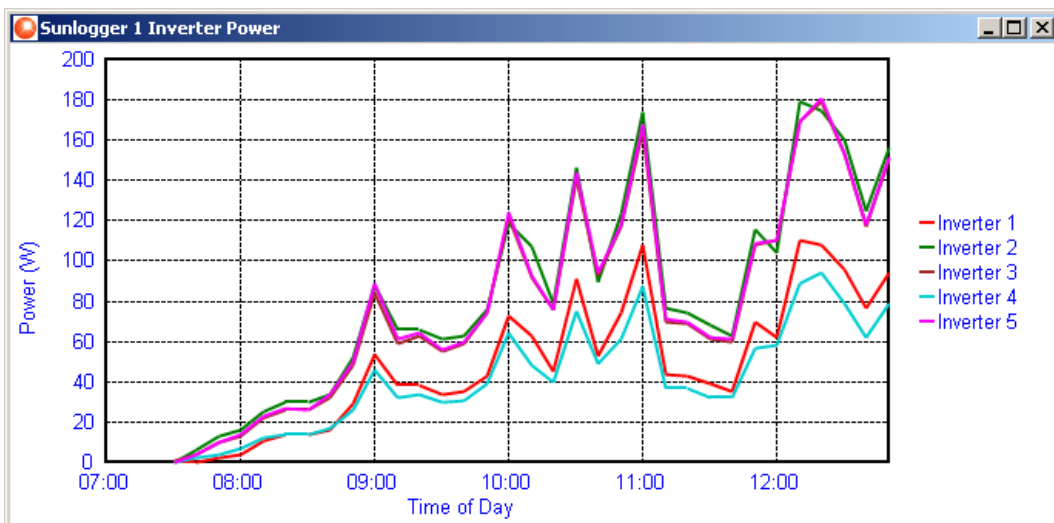
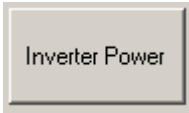

plot of individual inverter power output

## Switching between two Sunloggers

If you are using **Sundown** to monitor two **Sunloggers**, you can generate plots for either **Sunlogger**, or for both **Sunloggers** in combination.

To generate plots for **Sunlogger 1**, click on the **Sunlogger 1** button in the Control Panel.

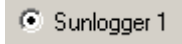

To generate plots for **Sunlogger 2**, click on the **Sunlogger 2** button in the Control Panel.



To generate plots for the combined power outputs of both **Sunloggers**, click on the **Totals** button in the Control Panel.

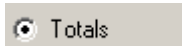

## Plotting historical performance

To generate a plot showing the historical output of your **/Plug & Power/** system, click on the **Historical** button in the Control Panel then click on the button corresponding to your **Sunlogger** (labelled **Sunlogger 1** or **Sunlogger 2**).

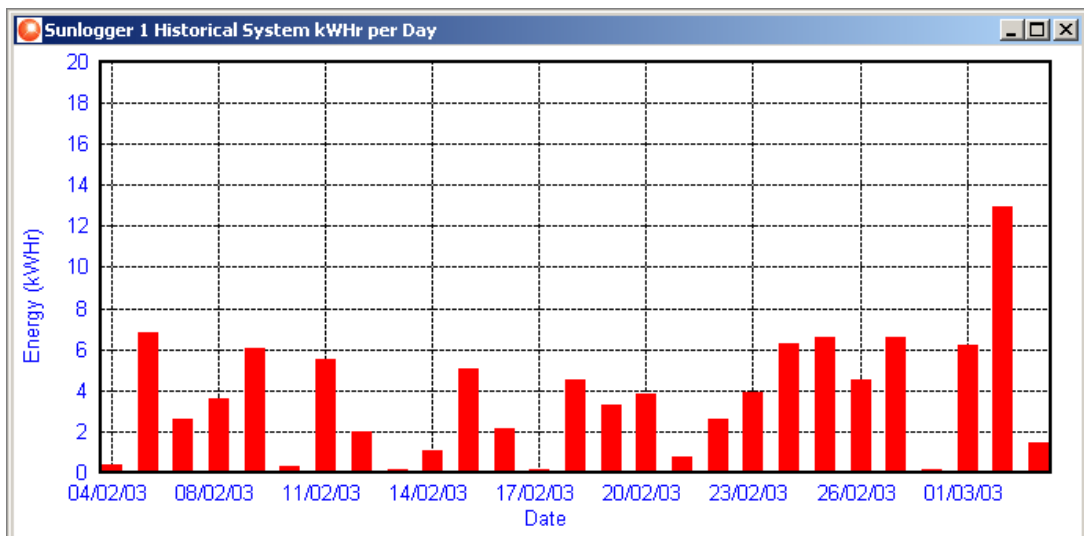
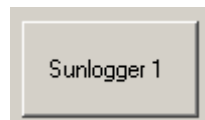
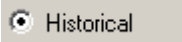

Plot of historical system power output

## Printing plots

To print a plot, select **Print Graph** from the **File** menu when a plot is open. Alternatively, you can click on the **Print** button.

You can change the print options by selection the **Print Setup** option from the **File** menu.

## Displaying a plot legend

To display a plot legend, select **Show Legend** from the **Graph Options** menu. Repeating the procedure will remove the legend from the plot.

Other graph display options are accessed from the **Graph Options** menu in a similar manner.

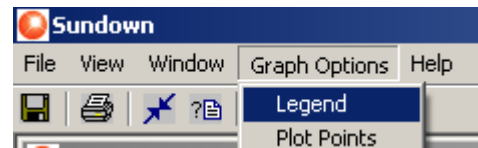
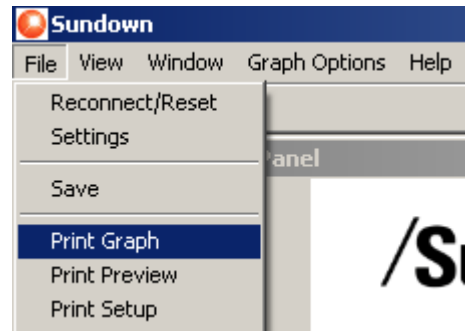

# Exporting data from Sundown

At any point, you can export all plot data to a series of comma separated variable (CSV) files.

## ► To export data from Sundown

- 1 If necessary, generate a plot window by clicking on one of the plot buttons.
- 2 From **File Menu**, click **Save**.
- 3 Once the data have been successfully exported, a confirmation message will be displayed. Click **OK**.

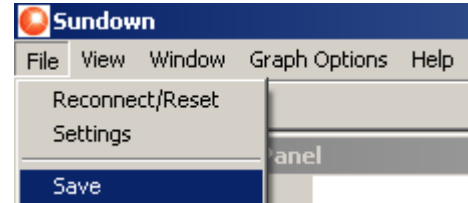



---

A P P E N D I X

# Energy efficiency

# Energy efficiency

The following tips can help you make your home more energy-efficient to further reduce your electricity bills and help the environment. When combined with a **/Plug & Power/** system, an energy efficient home can have little or no greenhouse gas emissions.

## Heating and cooling

**Insulate your home.** Keep your home warm in winter and cool in summer by installing insulation in the ceiling and walls, and by plugging any gaps around windows or doors.

**Use gas instead of electricity.** Using gas for cooking, water heating or space heating is cheaper than electricity and greatly reduces your CO<sub>2</sub> emissions.

**Use shades and blinds.** On hot days, use shades or blinds to keep the sun out and your house cool. On cold nights, do the same to keep heat in.

**Don't overheat or overcool.** Heating or cooling your home by an additional 34°F adds about 10% to your energy bill.

**Replace air-conditioner filters.** Dirty filters restrict air flow and make the air conditioner less efficient, increasing electricity use.

## Lighting and appliances

**Use energy-efficient lighting.** Not only do energy-efficient lights, such as compact fluorescent bulbs, last longer than conventional light bulbs, they can cut the amount of electricity used for lighting by up to 80%.

**Buy energy-efficient appliances.** When shopping for household appliances such as refrigerators, dishwashers and washing machines, look for a five or six-star rating. Such appliances will save energy and be cheaper to run.

**Replace refrigerator seals.** Leaky seals on a refrigerator waste energy and can cause food to spoil.

**Avoid excessive use of energy-intensive appliances.** Appliances such as clothes dryers and fan heaters use a lot of energy. Where possible, use alternatives such as a clothes line or gas heater.

## Hot water

**Choose the right hot water service.** When installing or replacing a hot water service, consider a solar or gas unit and look carefully at its star rating. The up-front cost may be higher, but the long term savings will make up for it.

**Install a AAA-rated shower head.** A water-efficient shower head can reduce both your electricity and water bills at the same time, and save about a ton of CO<sub>2</sub> per year.

**Turn down the thermostat.** If your hot water service has an adjustable thermostat, turn it down to 140°F to reduce energy loss. The water will still be more than hot enough for showers and washing.

**Fix dripping taps.** A dripping hot water tap can waste 100 kg of CO<sub>2</sub> every year. Also fix any leaks from your hot water service.

**Use cold water instead of hot wherever possible.** Washing laundry with a suitable detergent in cold water saves energy and protects your clothes from shrinkage.